

F. Giovacchini, S. Micera, M. Carrozza, P. Dario. Design of the new version of the mechatronic system for motor recovery after stroke (memos). *Gerontechnology* 2008; 7(2):112. In order to verify the possibility of improving motor recovery of hemiparetic subjects by using a simple mechatronic system, a system named 'MEchatronic system for MOtor recovery after Stroke' (MEMOS) was designed<sup>1</sup>. The MEMOS design was based on mainly 'off-the-shelf products' with only few parts simply manufactured with standard technology, when commercial parts were not available. The MEMOS system was used during clinical trials with subjects affected by chronic hemiparesis<sup>2</sup>. The results obtained during these experiments show that notwithstanding the simple mechatronic structure characterizing the MEMOS system, it is able to help chronic hemiparetics to reduce their level of impairment. MEMOS is a planar robot in a cartesian configuration. The work plane is a rectangular shape area allowing the patient's movement during the rehabilitation. Two perpendicular linear guide rails move the handle in the workspace. The actuation of the MEMOS device is achieved by using two DC motors and the transmission is performed by timing belt. The MEMOS system is equipped with a handle fixed to a trolley that is moving in a horizontal (XY) plane thanks to the mechatronic structure previously described. A force transducer is located at the base of the handle near the fixation point so as to obtain an estimation of the patient's exerted force in the X (lateral) and Y (front to back) directions. A new version of MEMOS is under designing in order to overcome some mechanical problems of the first version of MEMOS, which were mainly represented by inertia of the linear guide rails and anisotropy of the transmission. **Methods** The new system (*Figure 1*) is composed of two crossed ball screws each one powered by a DC motor. The extremities of each ball screw are supported each one by a bearing mounted on a linear track and thus each ball screw moves perpendicularly respect to the other screw. The two nuts of the ball screws are linked between them so that the rotation of a screw (powered by the motor) causes the movement of the other one. A handle is mounted on the connection unit of the nuts in order to control the handle movement by means of the one or both the motors. The patient grasps the handle which has a sensor at the bottom that can measure the forces applied by the upper limb. The improvement of the new MEMOS is the possibility to tilt the work-plane around two perpendicular axis in order to monitor the recovery in relation to the position of the plane. An additional feature of the new MEMOS is the reduced dimension of the workspace (400x500mm) that allows to obtain a more compact system easy to carry and to store (total dimension: 900x600x450 mm). **Results and discussion** The new MEMOS is under fabrication. The first prototype will be tested during the clinical experimentation planned with post-stroke patients.

#### References

1. Micera S, Carrozza MC, Guglielmelli E, Cappiello G, Zaccone F, Freschi C, Colombo R, Mazzone A, Delconte C, Pisano F, Minuco G, Dario P. *Autonomous Robots* 2005;19:271-284
2. Colombo R, Pisano F, Micera S, Mazzone A, Delconte C, Carrozza MC, Dario P, Minuco G. *Neurorehabilitation and Neural Repair* 2008;22:50-63

**Keywords:** robotics, neuro-rehabilitation, upper limb

**Address:** Scuola Superiore Sant'Anna, Italy; E: micera@sssups.it

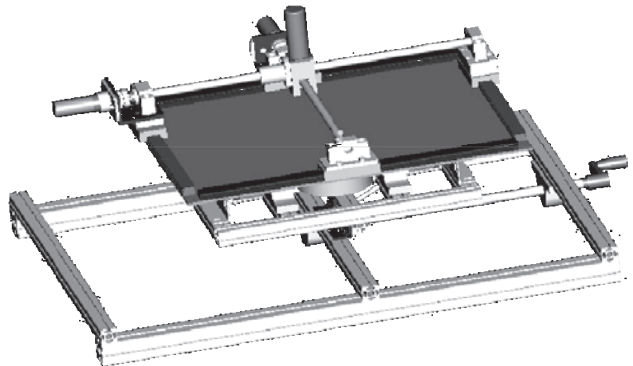

Figure 1 CAD model of the new version of MEMOS